

# α ALPHA CCH / CCR-V / CCR-H

ALUMINIUM HOUSED  
COMPACT BRAKE RESISTORS with INTERNAL THERMO WATCH

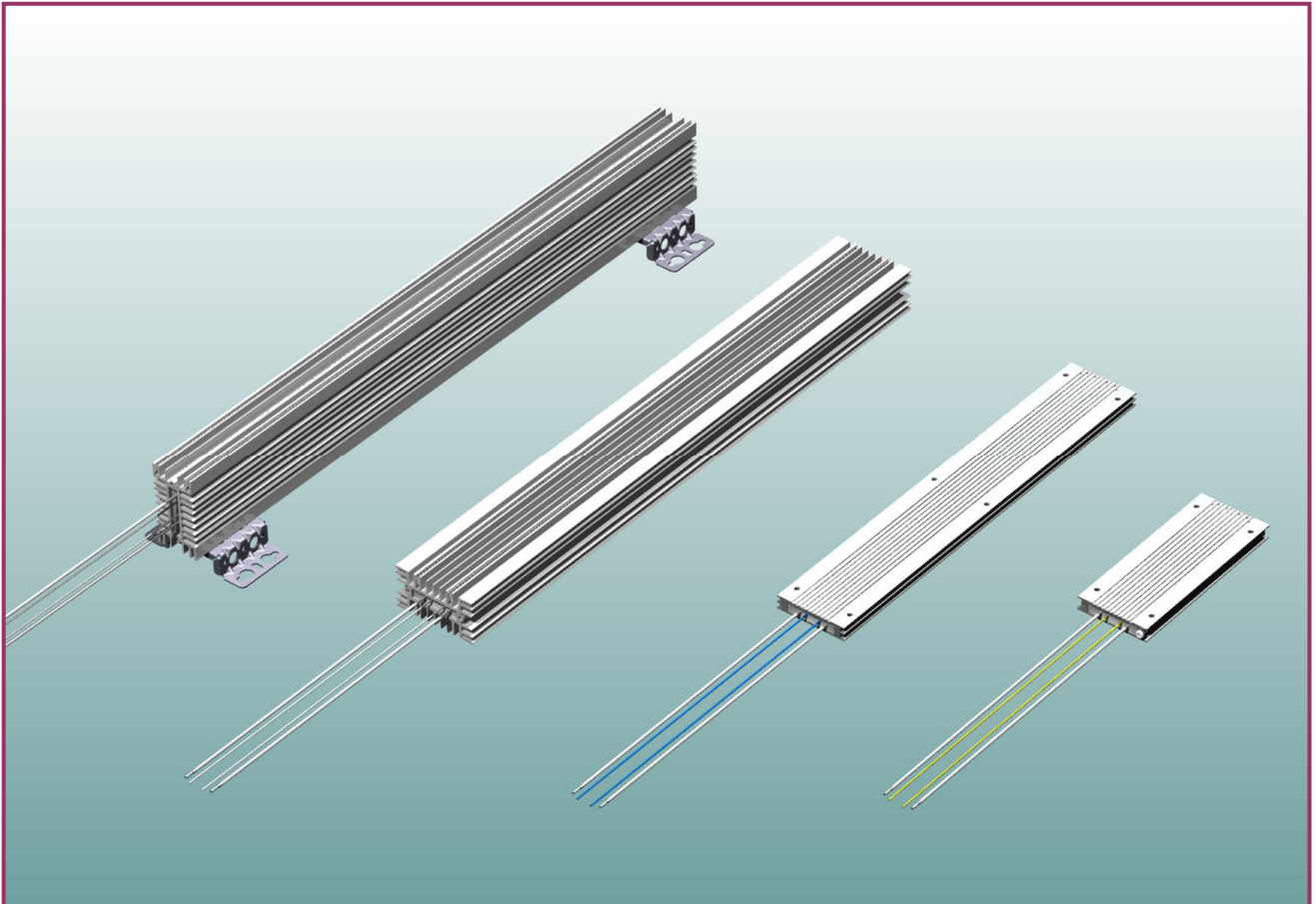

**CCH** and **CCR** belonging to our medium range of **ALUMINIUM HOUSED COMPACT ALPHA BRAKE RESISTORS** are insulated and can easily be integrated in compact constructions. They are constructed for high pulse loads compared to the average load.

The resistors comply with **IP50, IP52 or IP65** giving electrical and thermal protection. The resistors are Silicone free.

The power range is from **80W to 790 W** steady state load and pulse loads of 40 times compared to the nominal load in one second each 120s

The flat construction of CCH makes it suitable for heat sink cooling and can be used in **water cooled** equipment.

Danotherm has developed **thermal models** for all resistor types and resistor values. By using these models we are able to calculate the temperature rises in the resistor wire and on the surface for all possible load applications. We offer our assistance to our customers to find the optimum solution for any situation. All types can be offered with thermo watch. This range is generally approved to UL 508 (E208678), please consult Danotherm.



### Construction

The Alpha resistors are constructed as follows:

The resistor elements are wire wound elements wound on mica support sheets.

The housing is an aluminium profile, which is insulated with micanite sheets on all inner surfaces. The resistor elements are fixed symmetrical in the profiles by the mica construction. This ensures a symmetric expansion of the resistors and a maximum stability to high load impulses.

The resistor with the fixed resistor element is filled with quartz sand or MgO. This construction ensures a minimum change of temperature on the resistor surface even if the resistor element reaches its maximum temperature during a pulse load.

The resistors are approved to UL 508 for USA and Canada. All thermal data in this data sheet complies to UL 508 (no further reduction is required)

The standard cables are 300 mm AWG 16/14 Style 1659 PTFE for 600V types and 10724 for 1000V types, nature colour. We can supply cables in specified length, colours and mounted with cable shoes or connectors.

If screw terminals are required for the CCR types please use our **CCR-V XXX BT** or **CCR XXX DT** resistors with connection boxes.

If higher impulse/average load is required please consider the **CBR** or **CBT** types which have higher weight and heat capacity / length.

### PULSE LOAD

The curves show the pulse load ability compared to the nominal load for the CCH-CCR resistors under the following conditions: The load is a periodic pulse load with a constant period time of 120 sec.

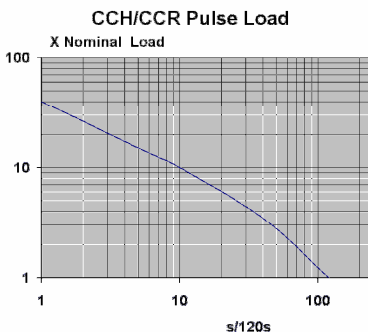

For further optimization DANOTHERM offers individual thermal electric circuit models for all types and ohm values. With these models the temperature of the resistor wire and resistor surface during any pulse load conditions can be simulated with a standard software like P-Spice. Alternatively Danotherm offers to make thermal simulation for our customers

### Ratings:

TYPE CCR(K)...C	PN W @40°C Approved UL508 C  US	Max Surface temp. °C @40°C	Pulse Load in 1 s each 120s. P1/120 kW @40°C	Pulse Load in 5 s each 120 s. P5/120 kW @40°C	Pulse Load in 10s each 120 s. P10/120 kW @40°C	Pulse Load in 40 s each 120 s. P40/120 W @40°C	Time Const sec.	R Ω (±5%) ±10%
CCH 135 CT	80	200	1.56	1.4	0.78	230	1000	2 - 1000
CCH 191 CT	120	205	2.5	2.25	1.25	370	1000	4 - 1200
CCH 241 CT	160	210	3.1	2.8	1.56	470	1000	6 - 1500
CCH 295 CT	200	210	3.9	3.5	1.99	600	1000	9 - 1700
CCH 345 CT	230	215	4.6	4.2	2.34	700	1000	10 - 2000
CCH 445 CT	300	220	6	5.4	3	910	1000	13 - 2000
CCH 545 CT	370	230	7.5	6.7	3.7	1120	1000	16 - 2000
CCH 645 CT	440	230	8.9	8	4.4	1330	1000	20 - 2000
CCR-V/CCR-H 135CT	140	230	3.4	1.9	0.91	410	1000	2 - 1000
CCR-V/CCR-H 191CT	190	250	8.3	2.6	1.9	760	1000	4 - 1200
CCR-V/CCR-H 241CT	250	255	11.8	3.4	2.8	990	1000	6 - 1500
CCR-V/CCR-H 295CT	300	260	13.7	4.1	3.4	1370	1000	9 - 1700
CCR-V/CCR-H 345CT	380	265	17.5	5.1	4.5	1520	1000	10 - 2000
CCR-V/CCR-H 445CT	480	275	21.3	6.5	5.3	2050	1000	13 - 2000
CCR-V/CCR-H 545CT	620	285	28.9	8.3	6.8	2660	1000	16 - 2000
CCR-V/CCR-H 645CT	790	290	32.7	10.7	8.3	3420	1000	20 - 2000

### General Specifications

Temperature Coefficient:	<±100ppm
Dielectric strength:	2500VAC 1 minute
Working Voltage:	UL: 600VAC / CE: 690VAC; 1100VDC
Isolation Resistance:	> 20 MΩ
Overload:	10 x in10 s / 120 s; 40 x in 1 s / 120 s
Environmental:	-40 °C – 90 °C
De-rating :	Linear: 40°C = P <sub>N</sub> to 90°C = 0.75*P <sub>N</sub>
Thermo watch contact :	N.C. 2A, 250VAC
Approvals	UL 508

PN: NOMINAL POWER WITH NATURAL COOLING WITH INTERNAL THERMO WATCH and CCH mounted in a horizontal position; CCR-V and CCR-H mounted in a vertical position. For data for resistors without internal thermostats please ask for special data sheet.

Colour code for T.W. cables: Brown = 130°C; Blue = 160°C; Orange = 180°C; White = 200°C

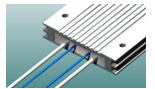

### Mechanical Data

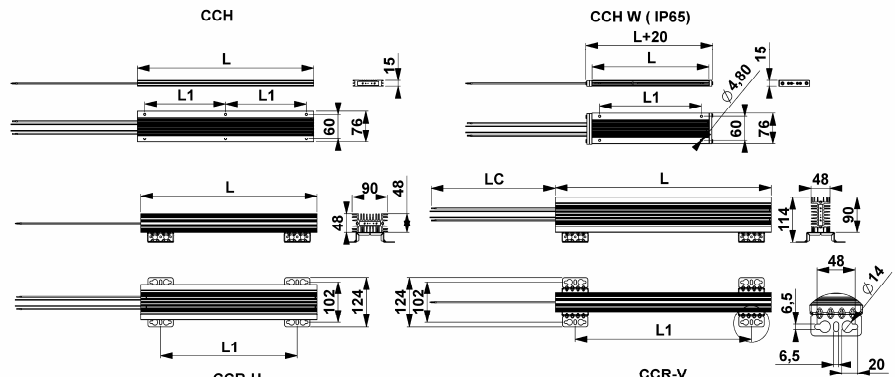

IP65 require extra length LT = L+20mm. L and L1 has the same value for IP50 and IP65.

The weight figures in the table below refer to IP50 versions. The table shows standard sizes. Other sizes are possible.

Type	L ± 2	L1±0.5	IP 65 L ± 2	W Kg	Type	L ± 2	L1 ±0.5	IP65 L ± 2	IP65: L1±0.5	W Kg
CCH 135 CT	135	98	135	0.27	CCR-V/CCR-H 135CT	135	-	135	-	0.61
CCH 191 CT	191	154	191	0.41	CCR-V/CCR-H 191CT	191	91	191	91	0.90
CCH 241 CT	241	204	241	0.54	CCR-V/CCR-H 241CT	241	141	241	141	1.1
CCH 295 CT	295	158	294	0.62	CCR-V/CCR-H 295CT	295	195	295	195	1.35
CCH 345 CT	345	2x154	345	0.85	CCR-V/CCR-H 345CT	345	245	345	245	1.58
CCH 445 CT	445	2x204	445	1.11	CCR-V/CCR-H 445CT	445	345	445	345	2.03
CCH 545 CT	545	2x241.5	545	1.36	CCR-V/CCR-H 545CT	545	445	545	445	2.46
CCH 645 CT	645	2x291.5	645	1.61	CCR-V/CCR-H 645CT	645	545	645	545	2.92

### Type identification:

**CCR-V (K) 326 (M) C T 22R 081**

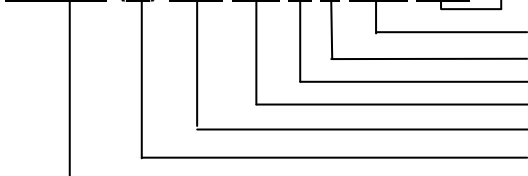

081 = Standard, 200 °C ; 071 = Standard 180 °C ; 061 = Standard 160 °C ; 051 = Standard 130 °C ; XXX > 400 customer specified version.

Ohm Value (Examples: 2R2=2.2Ω; 22R=22 Ω; 220R=220Ω; 2K2 = 2.2 kΩ )

T = Thermostat (200 °C is standard; please specify if other temperatures are required)

Terminals: C: Cable, W: Cables and IP65 (UL: Type 4X)

M MgO filling, (specified by Danotherm)

Length of resistor profile in mm.

K = 1000V; ( ) 600V (UL Approved)

Type CCH, CCR-V, CCR-H

NON UL versions: CCHX 335 C 22R 800