

THICK FILM POWER RESISTORS PR250

PR Series

FEATURES

Very good ratio Power / Volume
 Easy mounting and wiring with significant cost advantages.
 Non inductive performance for high frequency applications.
 One models for power applications up to 500W.
 Suited to ULV94-V0 application.

ELECTRICAL SPECIFICATIONS

Specifications

- Power rating: 250W (heatsink at 100°C)
- Resistance range: From 1R0 to 1M0hm, E12 series
- Tolerance: Standard 10%, up to 1% on request
- Temperature coefficient: ± 100 ppm/°C
- Max Work. Voltage: 5000 Vac
- Work Temp. Range: Da -55°C a +155°C
- Dielectric Strength: 7000 Vac (12000 Vac x PR250T)
- Insulation resistance: > 10⁸ MOhm at 500V
- Creep distance: 42 mm (65 mm x PR250T)
- Air gap distance: 16 mm (29mm x PR250T)
- Partial discharge: < 10 pC @ 5000 Vac
- Self inductance: 80 nH
- Parallel capacitance: 40 pF
- Capacitance to heatsink: < 120 pF
- Overload : 4 Pn x 10 s
- Thermal resistance: 0.15 °C/W
- Heatsink flatness: 0.05 mm Max
- Heatsink surface finish: 6.3 μ m Max
- Thermal grease: Required
- Max torque for contacts: 2Nm (static)
- Max torque for mounting: 2Nm (static)
- Weight: 100 g (130 gx PR250T)
- Options: - For values R039 <R< 1R0 is available Metal Foil type **PR250M**
 - Cable terminals **PR250C / PR250TC**

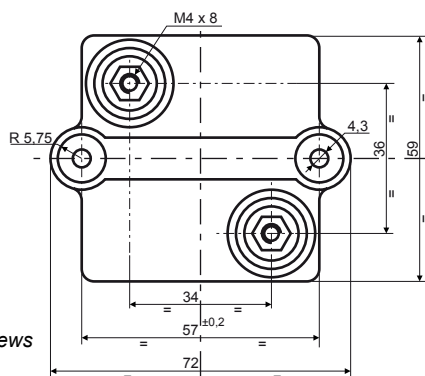
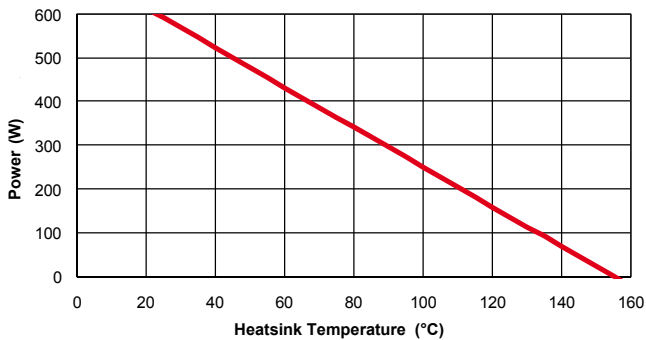

Connection and mounting screws supplied with the resistor

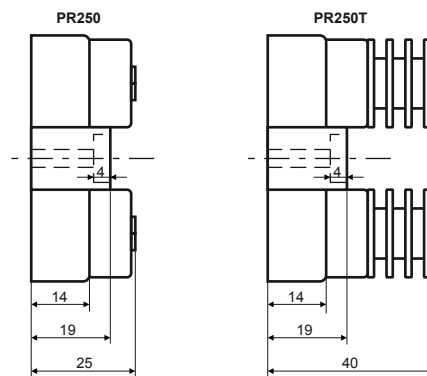

PR254 Thick film power resistors
PR254T

THICK FILM POWER RESISTORS PR254

PR Series

FEATURES

Very good ratio Power / Volume
Easy mounting and wiring with significant cost advantages.
Non inductive performance for high frequency applications.
One models for power applications up to 500W.
Suited to ULV94-V0 application.

ELECTRICAL SPECIFICATIONS

Specifications

- Power rating: 250W (heatsink at 100°C)
- Resistance range: From 1R0 to 1M0hm, E12 series
- Tolerance: Standard 10%, up to 1% on request
- Temperature coefficient: ± 100 ppm/°C
- Max Work. Voltage: 5000 Vac
- Work Temp. Range: From -55°C to +155°C
- Dielectric Strength: 7000 Vac (12000 Vac x PR254T)
- Insulation resistance: $> 10^8$ MOhm at 500V
- Creep distance: 42 mm (65 mm x PR254T)
- Air gap distance: 16 mm (29mm x PR254T)
- Partial discharge: < 10 pC @ 5000 Vac
- Self inductance: 80 nH
- Parallel capacitance: 40 pF
- Capacitance to heatsink: < 120 pF
- Overload : 4 Pn x 10 s
- Thermal resistance: 0.15 °C/W
- Heatsink flatness: 0.05 mm Max
- Heatsink surface finish: 6.3 μ m Max
- Thermal grease: Required
- Max torque for contacts: 2Nm (static)
- Max torque for mounting: 2Nm (static)
- Weight: 125 g (155 g x PR254T)
- Opzioni: Cable terminals PR254C / PR254TC

